



# Current Status of EFVs in Japan

Yoshio Kimura

(TOYOTA MOTOR CORPORATION)

Japan Automobile Manufacturers Association

# What's the Environmentally Friendly Vehicle (EFV) ?

- Low Exhaust Gas Emission
- Low CO<sub>2</sub> Emission
- Low Energy Consumption

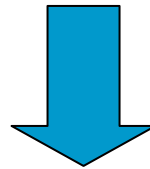

- |                     |                    |
|---------------------|--------------------|
| ■ Electric Vehicle  | <b>Past?</b>       |
| ■ Hybrid Vehicle    | <b>Soon coming</b> |
| ■ Fuel Cell Vehicle | <b>Future</b>      |

# Low Environmental Impact: Well to Wheel CO<sub>2</sub> Emission Comparison

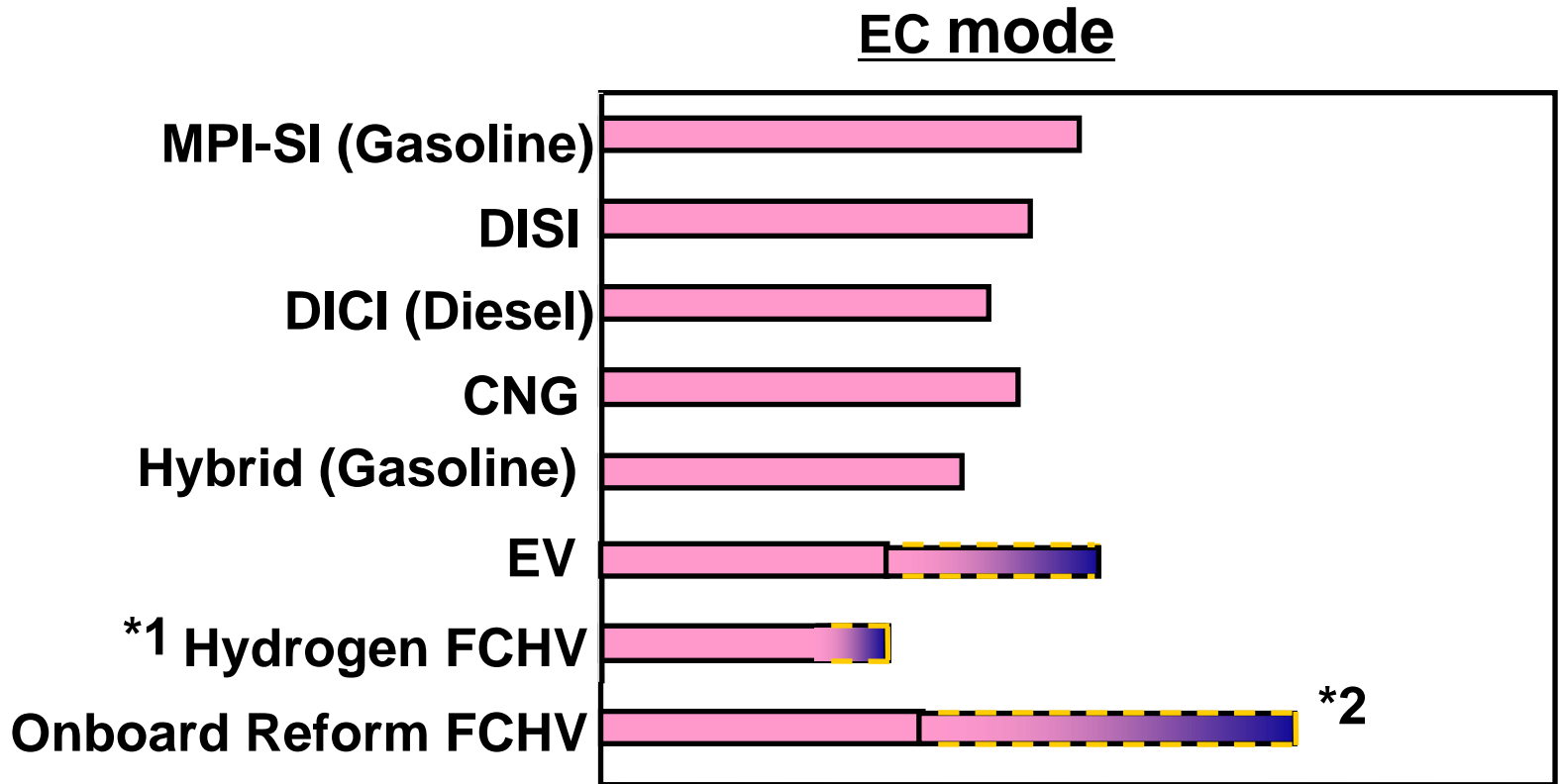

CO<sub>2</sub> emission (MPI-SI =1)

\*1: Derived from NG.

\*2: CO<sub>2</sub> emission of FCV is an estimation.



# EV Features

## ADVANTAGES

1. **No exhaust emissions directly from vehicle.**
2. **Various clean energy options for electric power generation.**
3. **Fuel conservation through high energy efficiency.**
4. **Recharging at night for electric load leveling.**
5. **Reduced vehicle noise.**

## DISADVANTAGES

- \* **Limited vehicle use due to high price and less than satisfactory driving performance.**

# EV Profile by Manufacturer

Manufacturer	Model	Driving Distance per Recharge (km) (10-15mode)	Max Speed (km/h)	Battery	Motor
SUZUKI	EVERY EV	110	95	Sealed Lead Acid	Synchronous Motor (permanent magnet)
DAIHATSU	HIJET	110	100		
TOYOTA	RAV4 V EV	215	125	Ni-MH	
	e-com	100	100		
NISSAN	Hypermini	115	100	Li-ion	
	R'nessa	230	120		
HONDA	HONDA EV Plus	222	130	Ni-MH	

# EVs in Use (Japan)

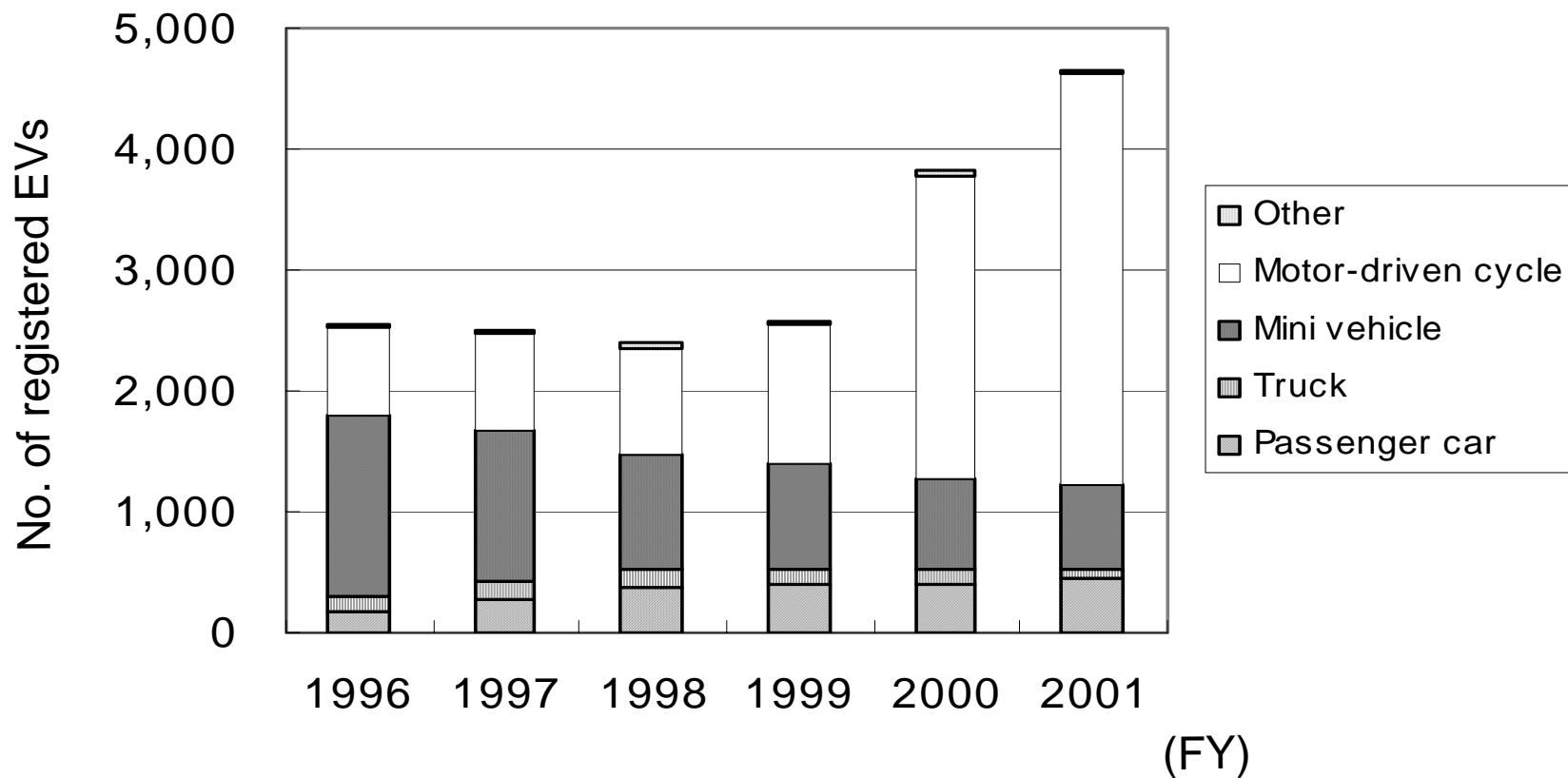

The use of EVs has remained at low levels.

# Cumulative Total of EV Sales/Leases (USA)

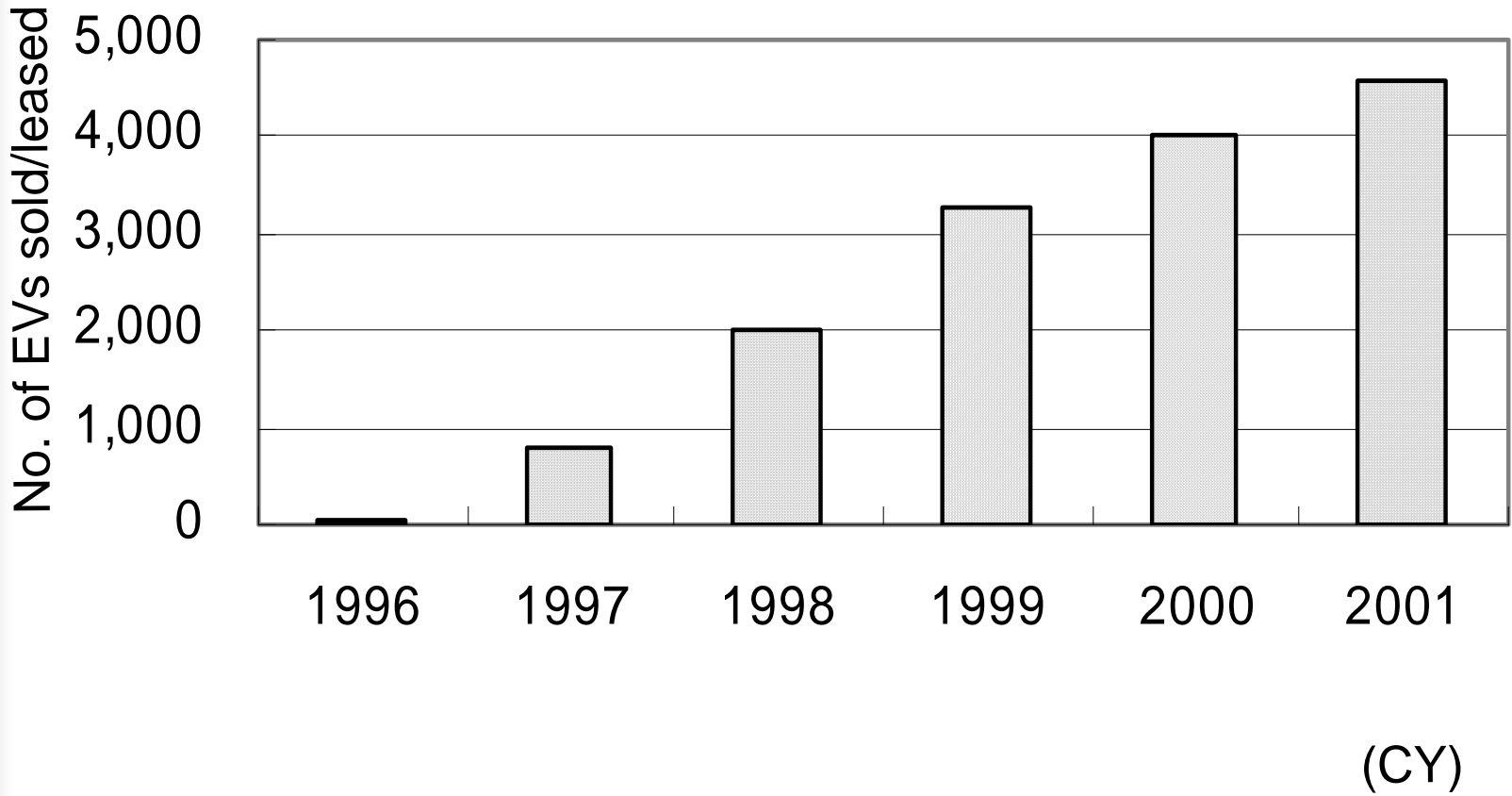

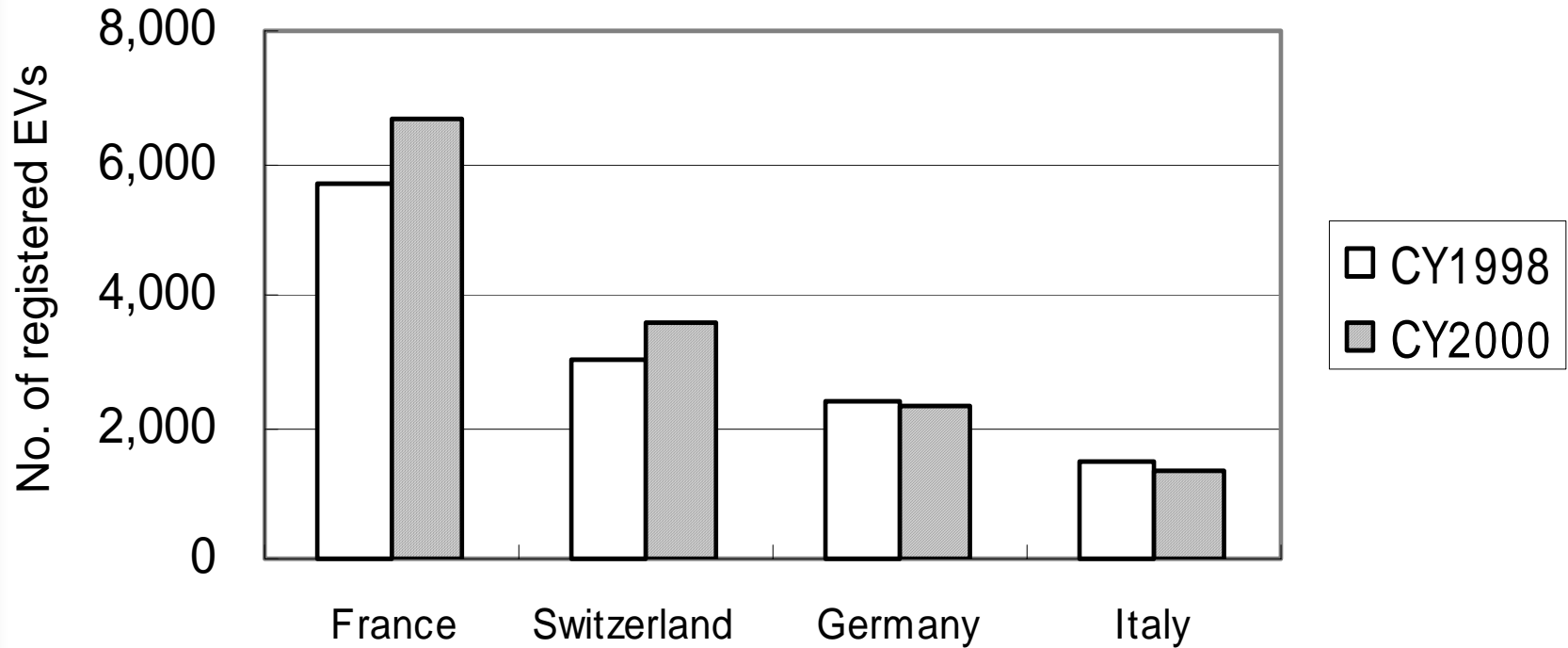

# EVs in Use (EU)

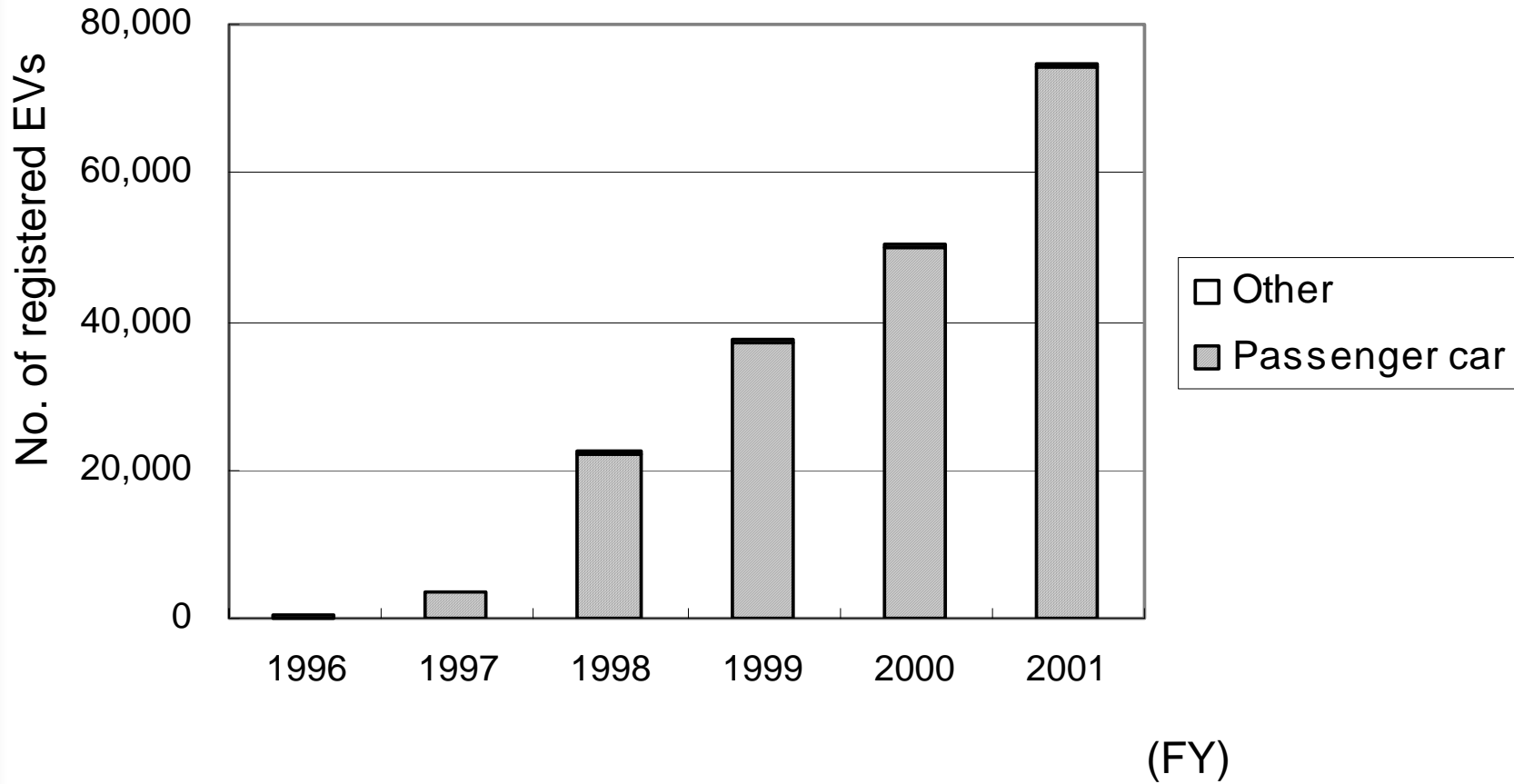

# HEVs in Use (Japan)



# Creating a Niche Market for Super Mini EVs

ARACO Everyday COMS		Takara Q-CAR
		
Vehicle Mass	270kg	375kg
D.D.*	80km	80km

\*Driving Distance Between Recharge

# Car Sharing System

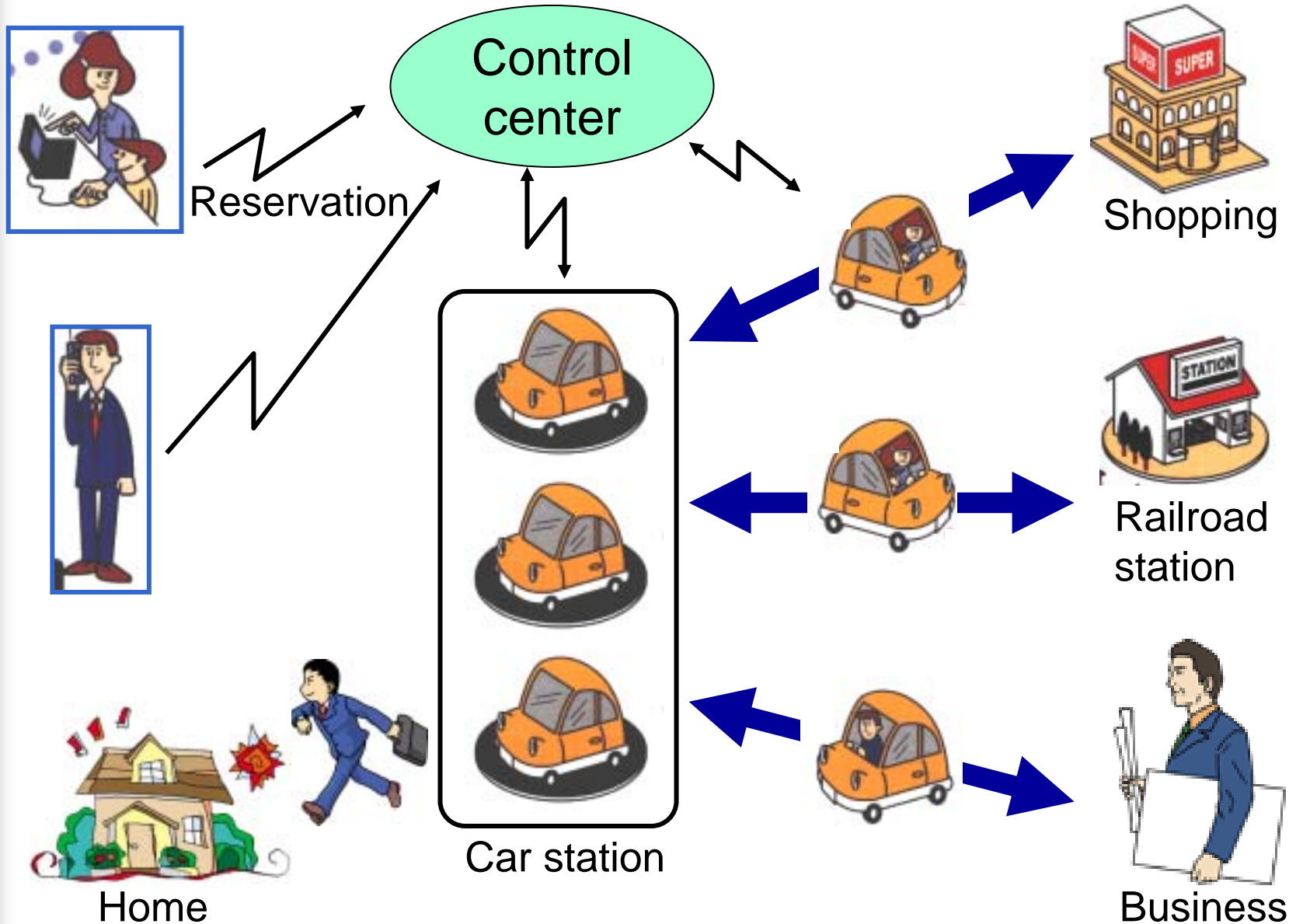

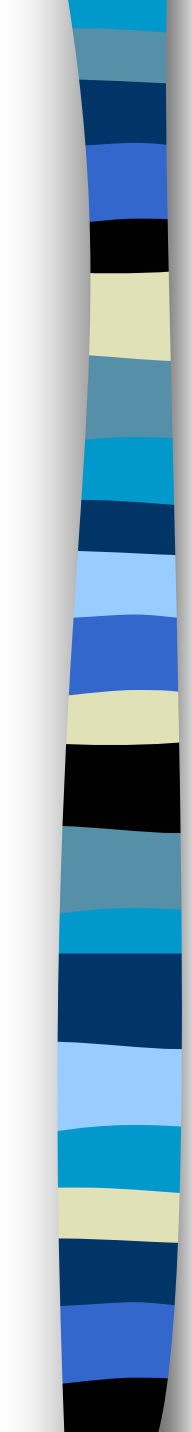

## What is the HEV?

- A vehicle with two power plants (motor and engine) and/or with two energies stored (fuel and batteries or capacitors).
- Realizes high fuel economy and clean emission by recovering the braking energy and operating the engine only in the high-efficiency and low-emission mode.





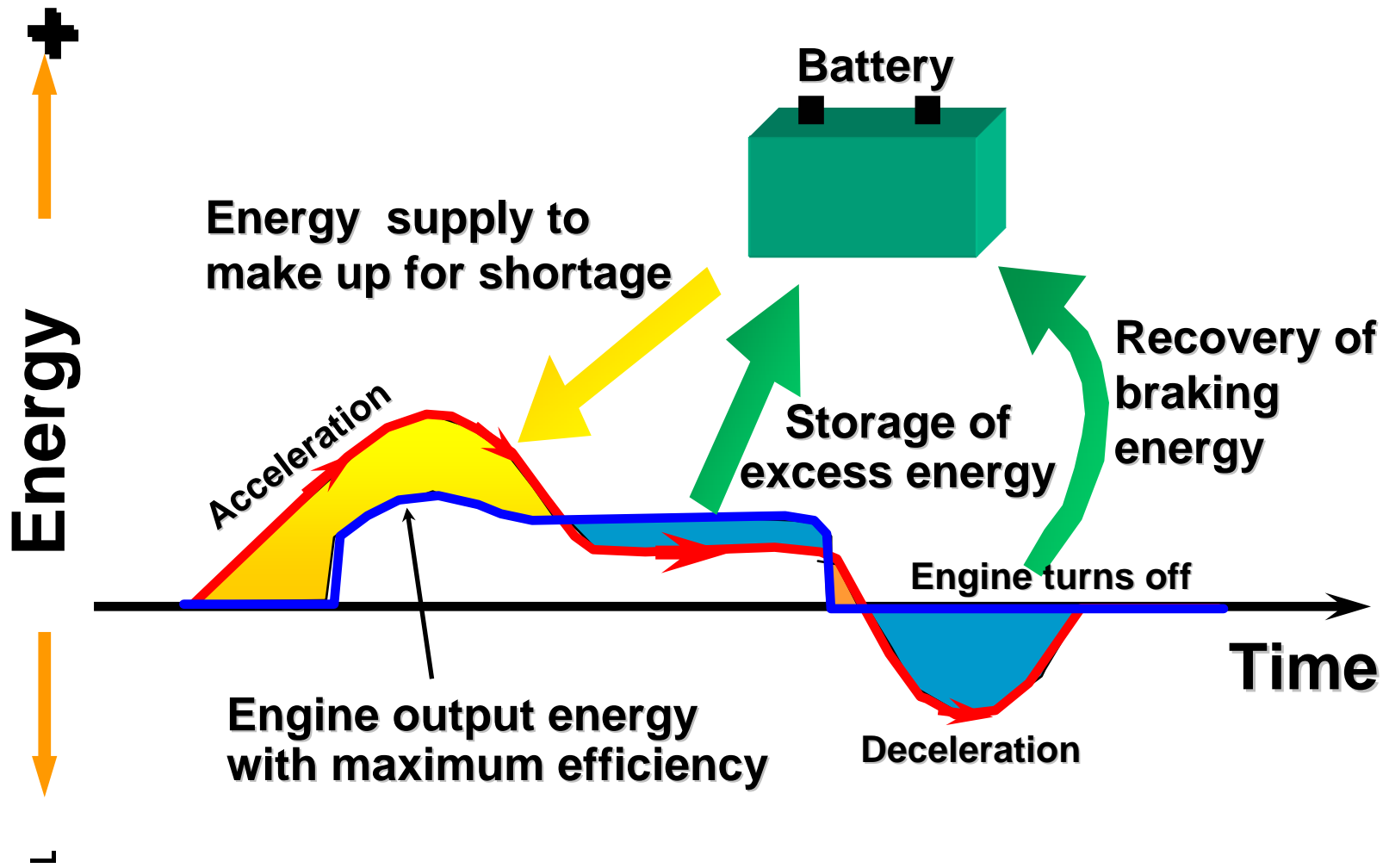

# **EV Issues**

- 1. High price**
- 2. Short driving distance between recharge**
- 3. Long recharge time**
- 4. Underdeveloped recharge infrastructure**
- 5. Short battery service life**

# HEV Energy Management

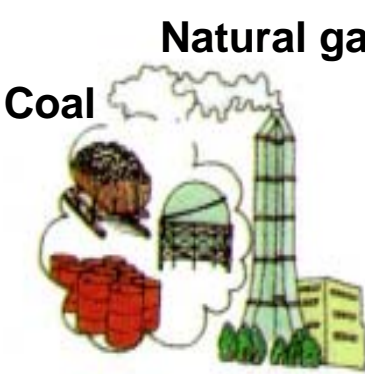
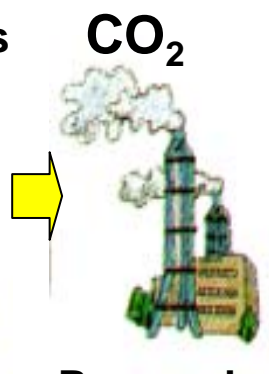
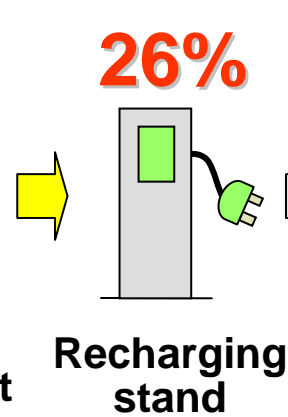
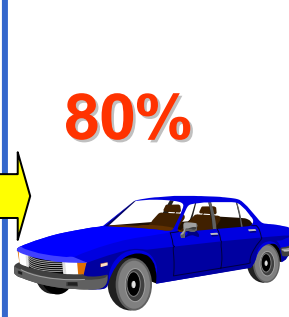

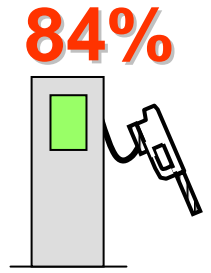
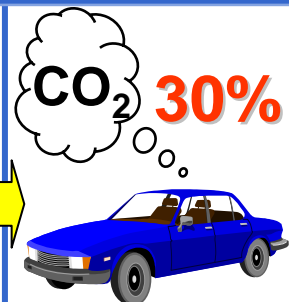
# EV-HEV Energy Comparison

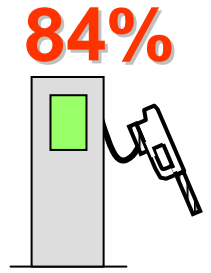
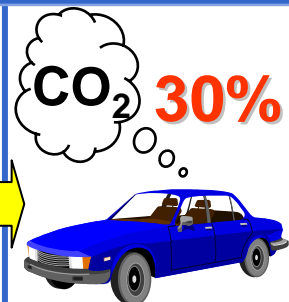
	<i>Well to tank</i>			<i>Tank to wheel</i>	<i>Well to wheel</i>
<b>EV</b>	 <p>Coal Natural gas Petroleum</p>	 <p>CO<sub>2</sub> Power plant</p>	 <p><b>26%</b> Recharging stand</p>	 <p><b>80%</b></p>	<p><b>21%</b></p>
<b>HEV</b>	 <p>Petroleum</p>	 <p>Refinery</p>	 <p><b>84%</b> Gasoline station</p>	 <p>CO<sub>2</sub> <b>30%</b> <b>15%</b></p>	<p><b>25%</b></p>
<b>ICE</b>	 <p>Petroleum</p>	 <p>Refinery</p>	 <p>Gasoline station</p>	 <p><b>15%</b></p>	<p><b>13%</b></p>

# HEV Driving Systems

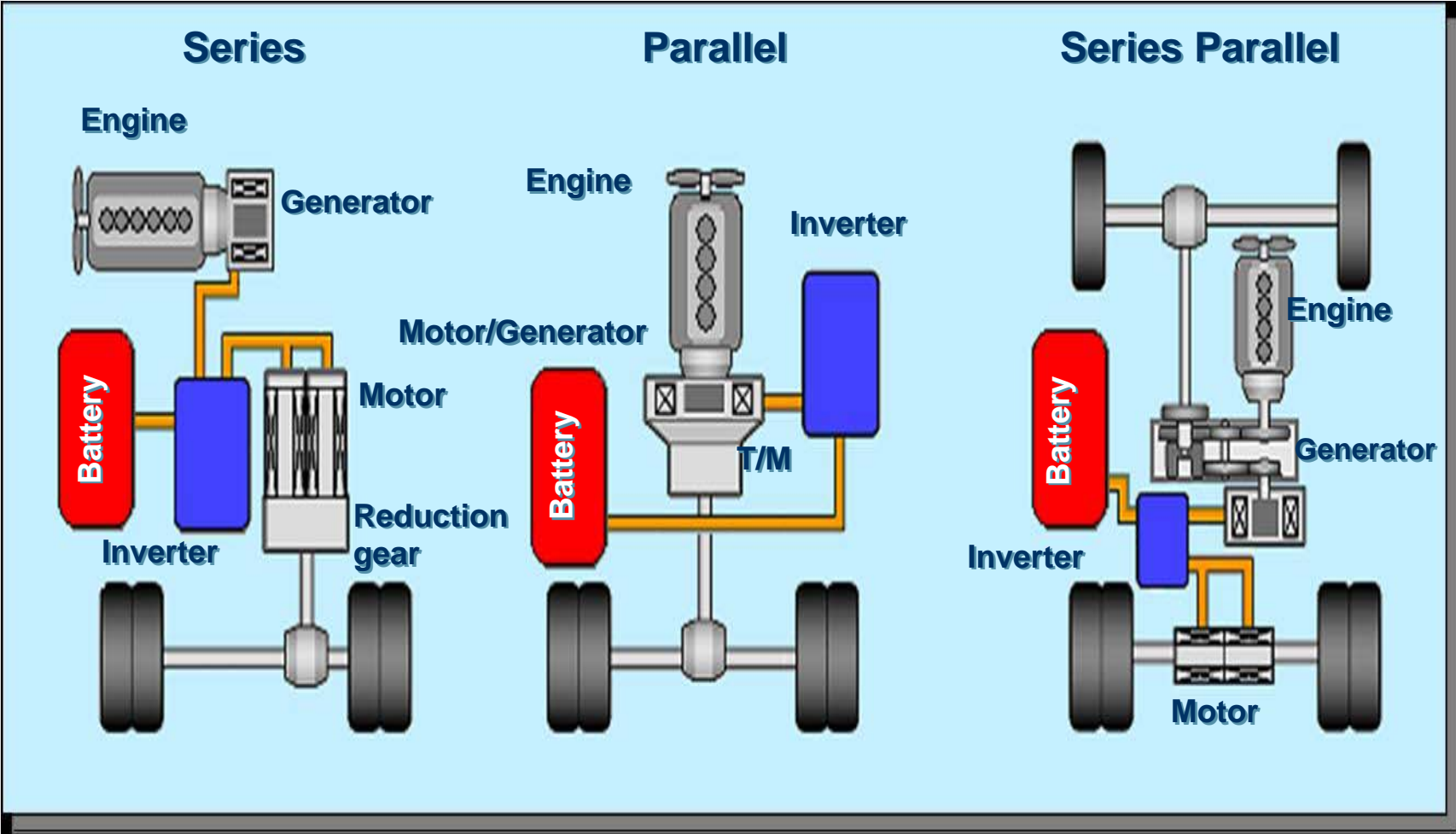

# Hybrid Vehicles in Japan's Market

	Mini car	Small car	Small commercial vehicle	Large commercial vehicle
<b>Series</b>			Coaster ( <i>TOYOTA</i> )	AERO STAR ( <i>mitsubishi FUSO</i> )
<b>Parallel</b>	Twin ( <i>SUZUKI</i> )	Insight ( <i>HONDA</i> )  Civic ( <i>HONDA</i> )	DINA, Dutro  ( <i>TOYOTA, HINO</i> )	Condor  ( <i>NISSAN DIESEL</i> )
<b>Series Parallel</b>		Prius, Estima, Alphard ( <i>TOYOTA</i> ) Tino ( <i>NISSAN</i> )		

# SUZUKI Hybrid System



*Twin*

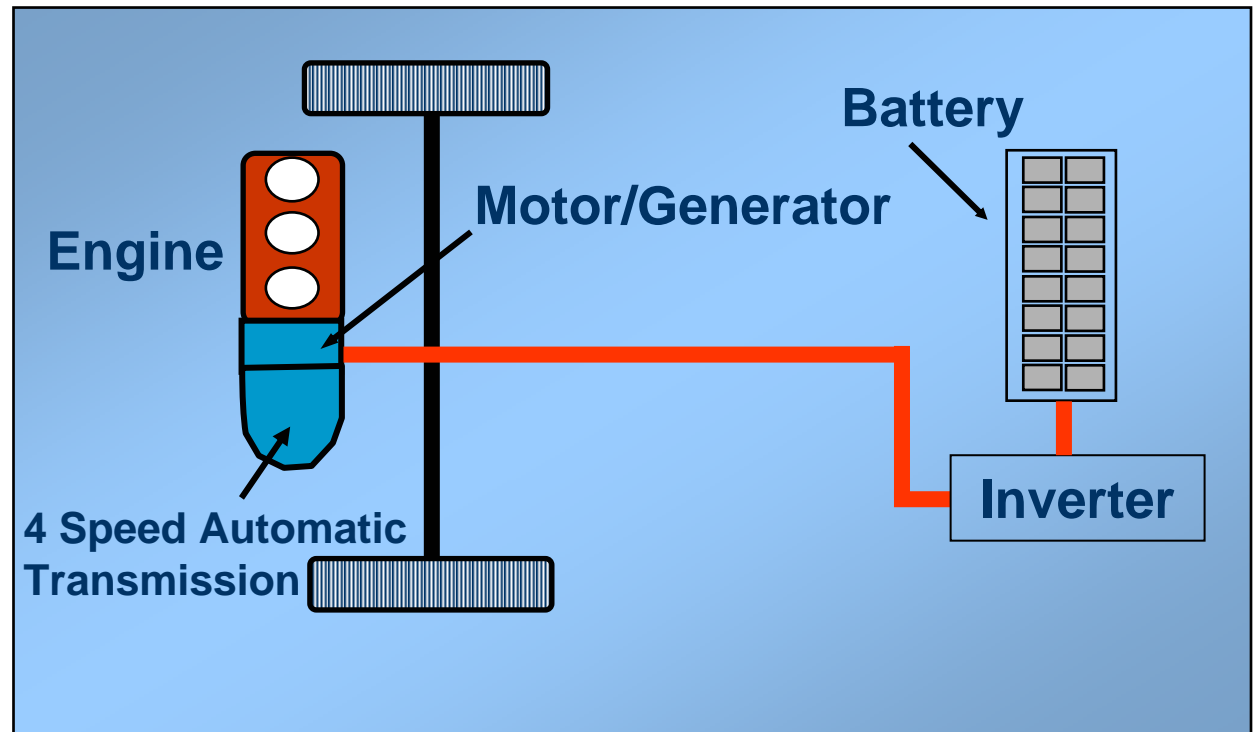

# TOYOTA Hybrid System (THS)



*Prius*

**Power Split Type Hybrid  
(Series Parallel)**

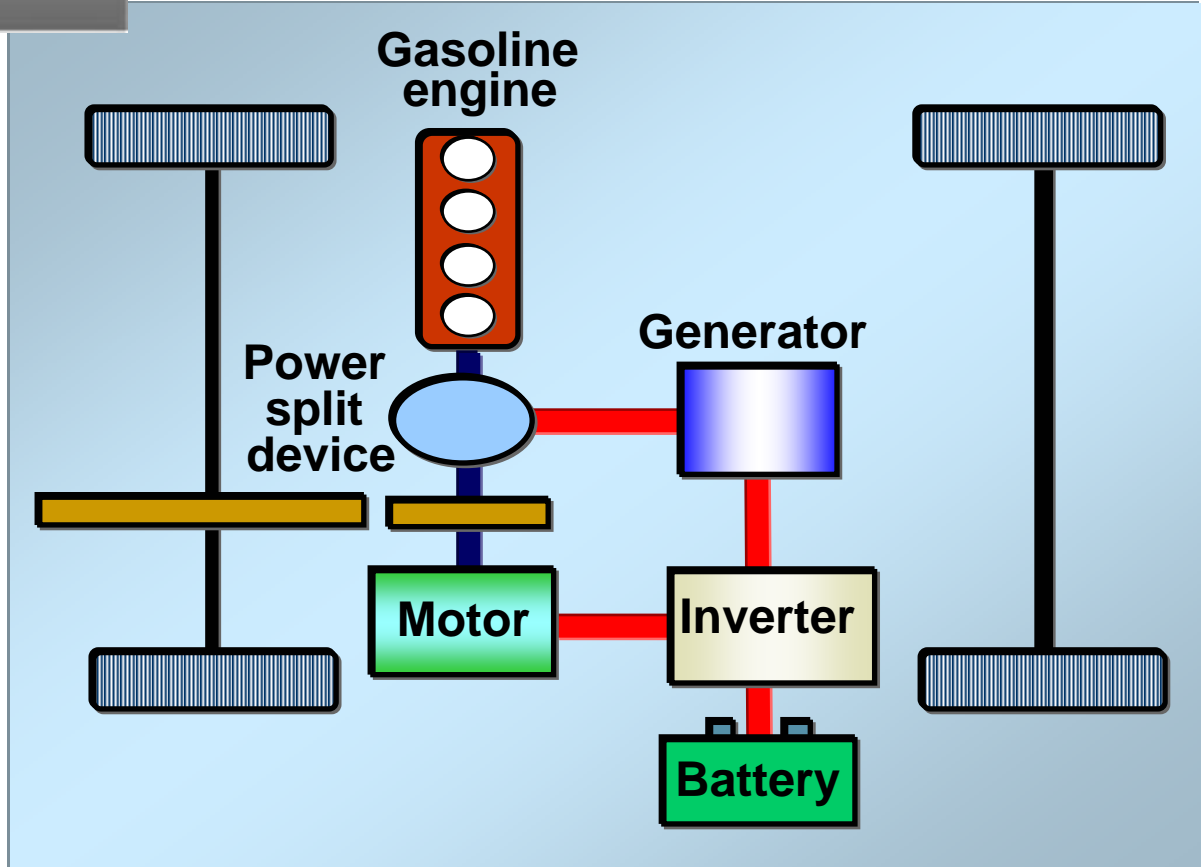

# NISSAN NEO Hybrid System



*Tino*

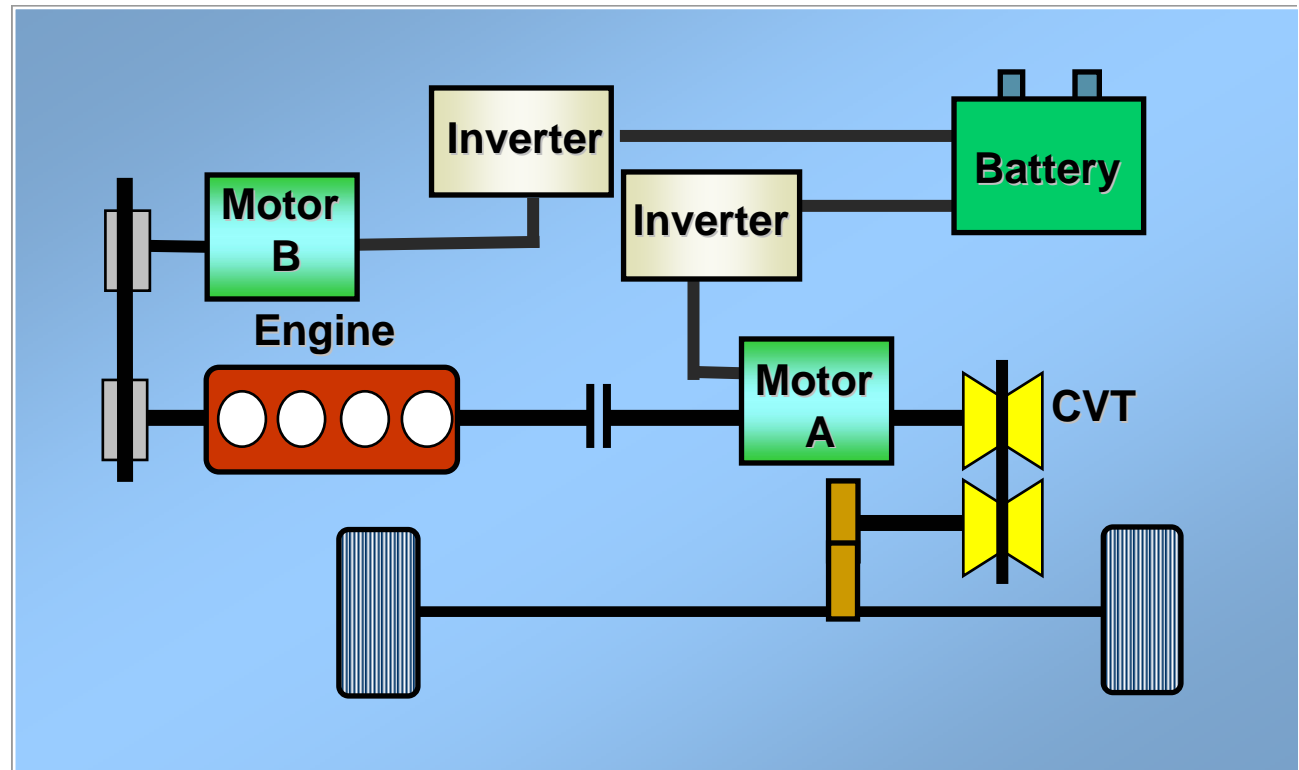

# HONDA IMA System



**Civic**

**HONDA IMA\* System**  
(\* Integrated Motor Assist)

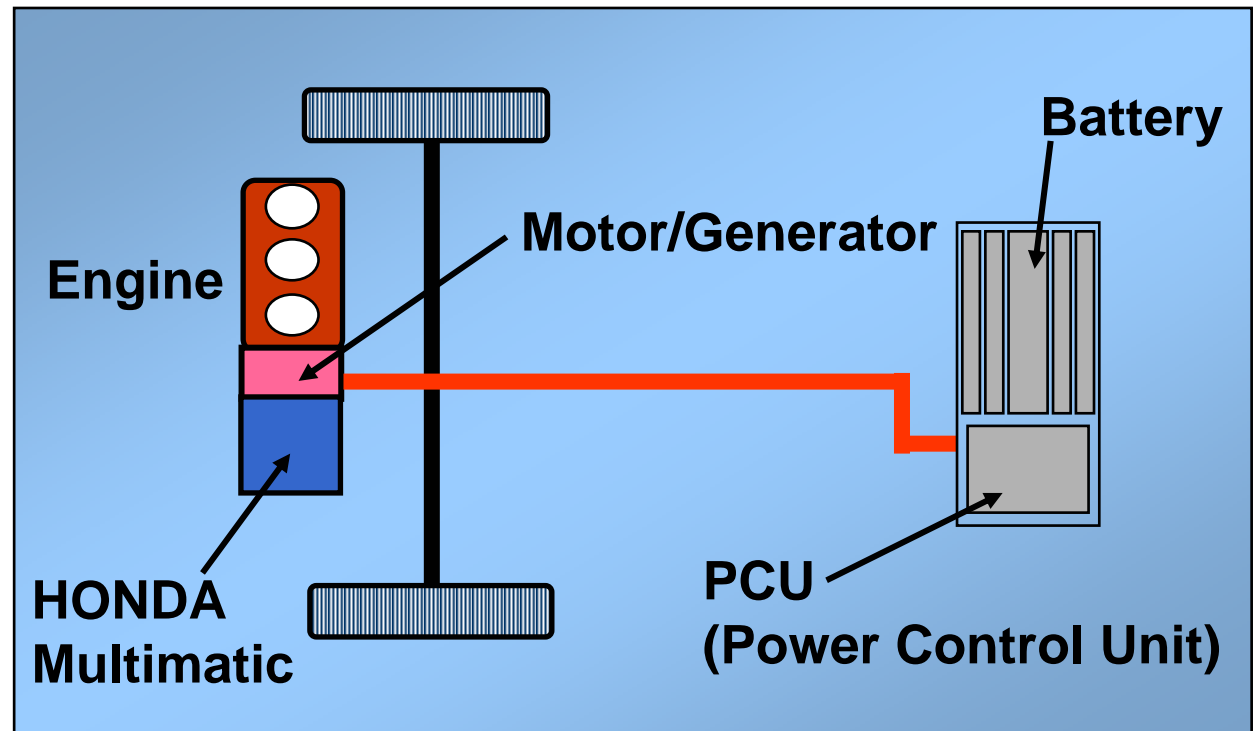

# NISSAN DIESEL Capacitor Hybrid M.D. Truck



NISSAN DIESEL  
Super Power Capacitor™  
Max. 346V,583Wh

2002.6 Release

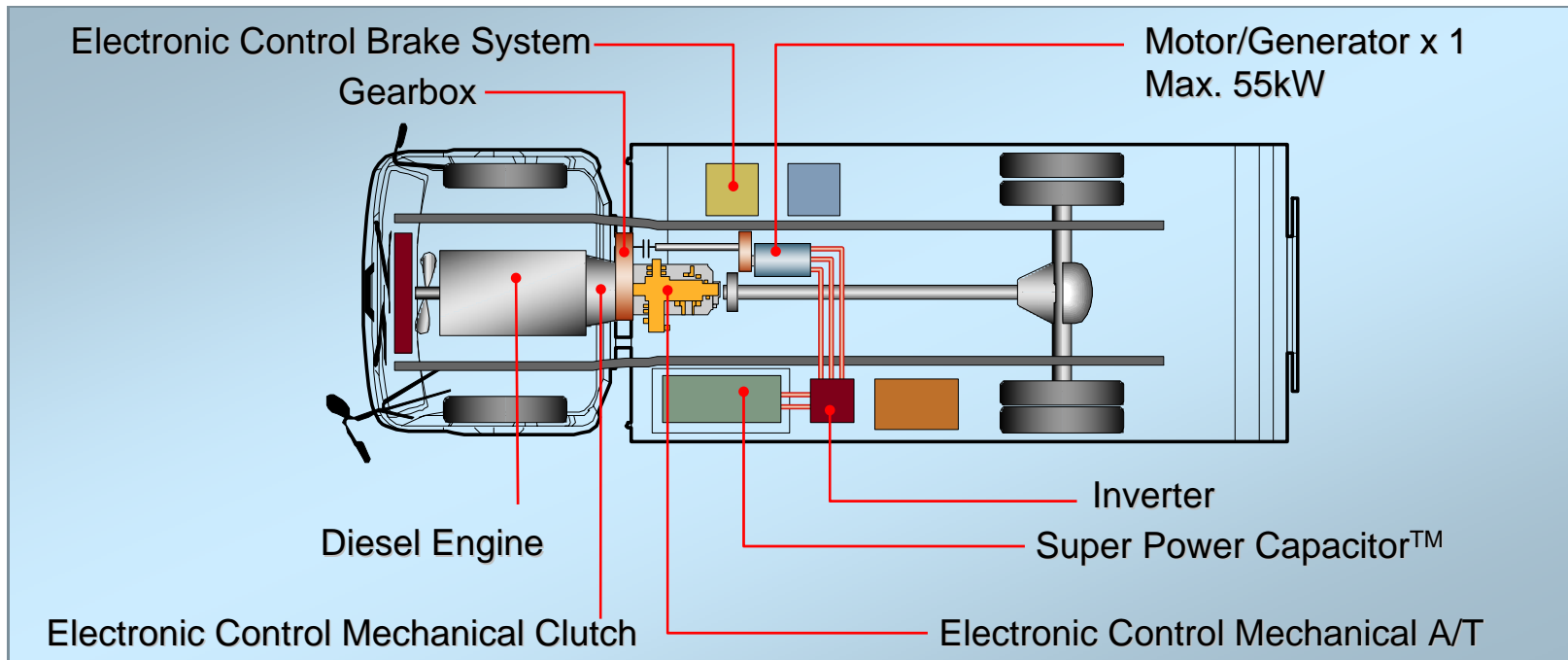

# HINO Parallel Hybrid Bus (HIMR)

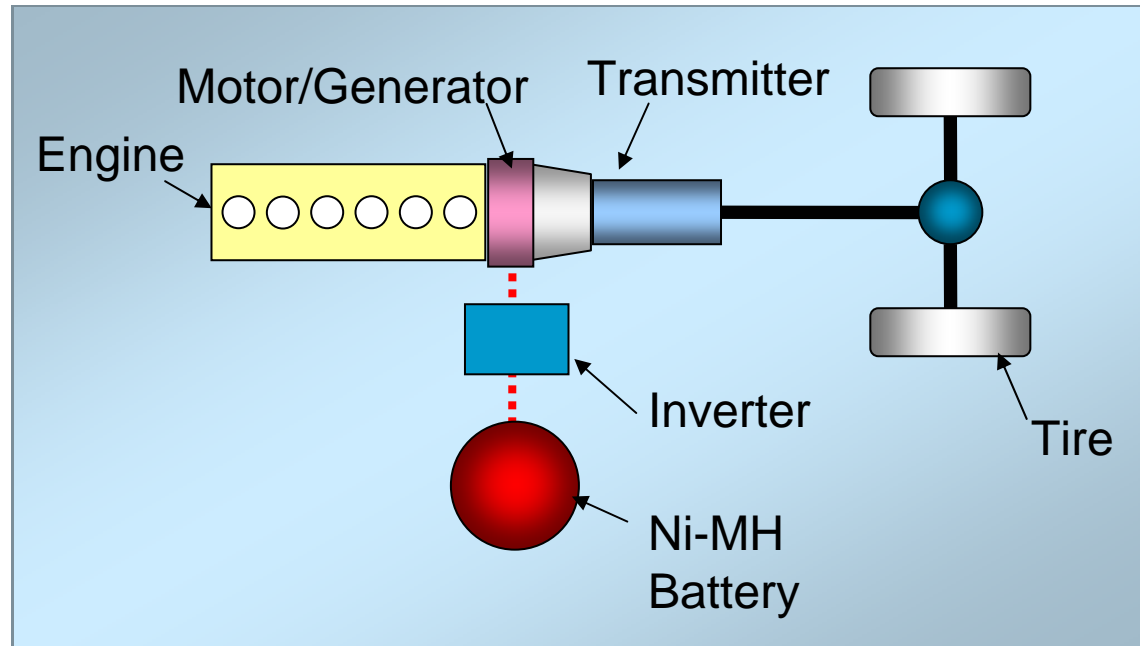

Release '91/12 -

Second generation type '96/2 -

Third generation type '01/7 -

# HINO Parallel Hybrid Truck

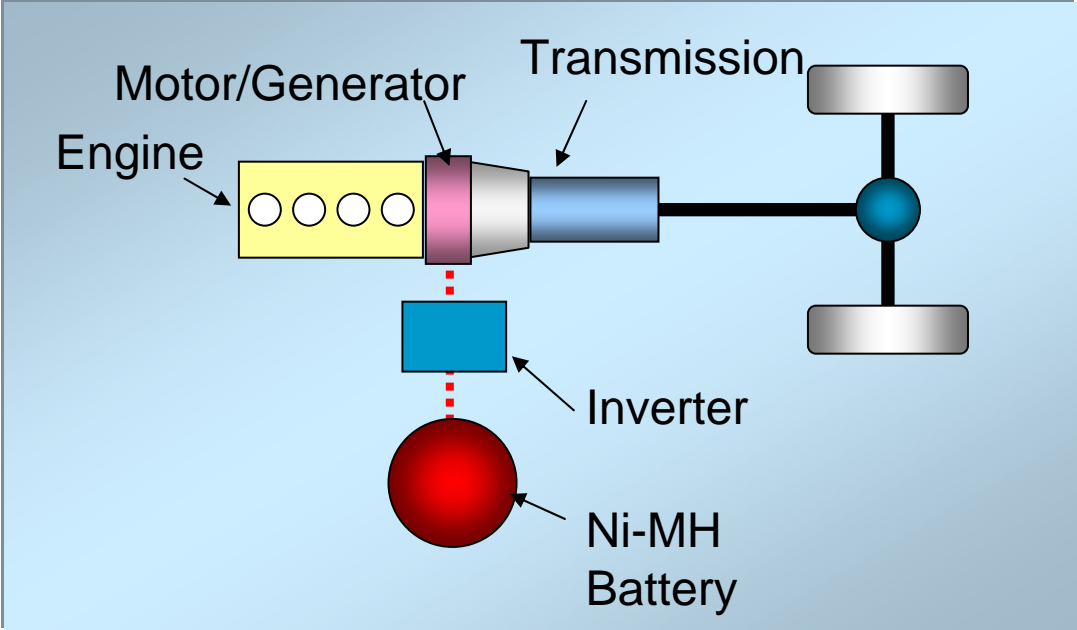

# MITSUBISHI FUSO Series Hybrid Bus



**AERO NONSTEP HEV**

## Series Hybrid System

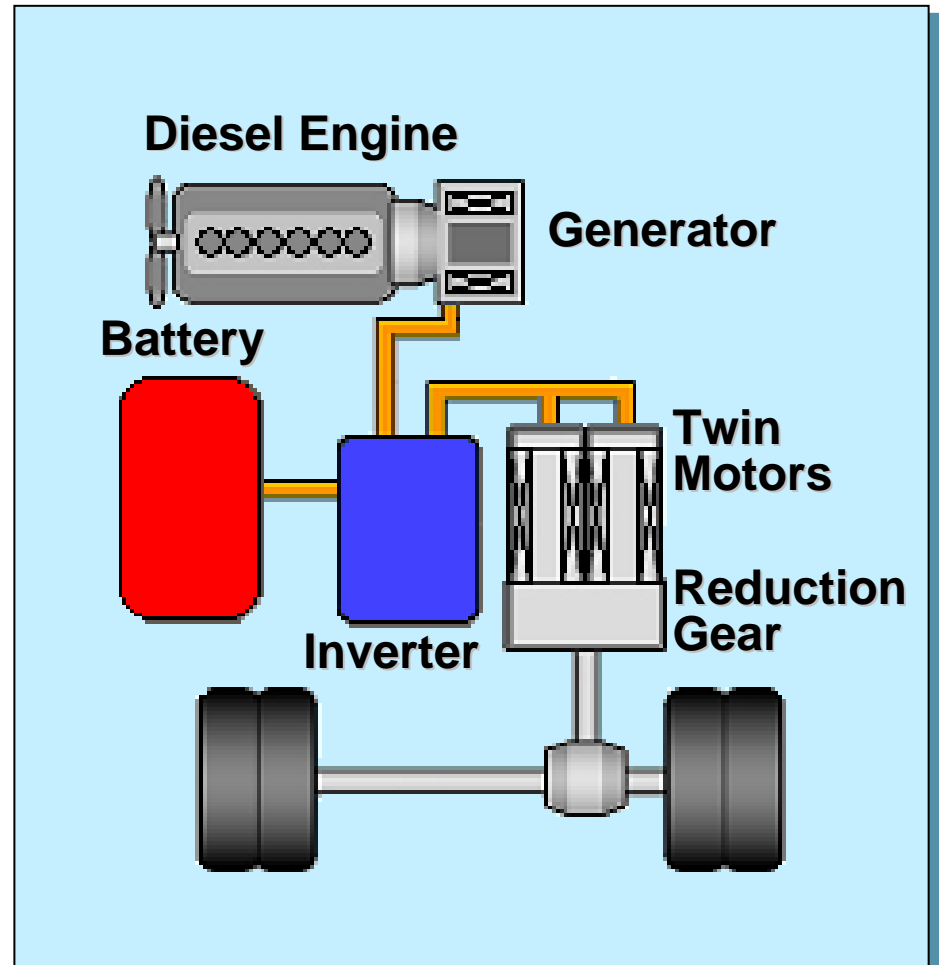

# Why Fuel Cell Vehicle?

## High efficiency

High energy efficiency compared to ICE (internal combustion engines).

## Clean

No CO<sub>2</sub>, NO<sub>x</sub>, HC.

## Hydrogen

Fuel Cell uses hydrogen as its fuel.  
(Hydrogen is a key energy for the future.)

## Oil Free

# Fuel Cell Structure

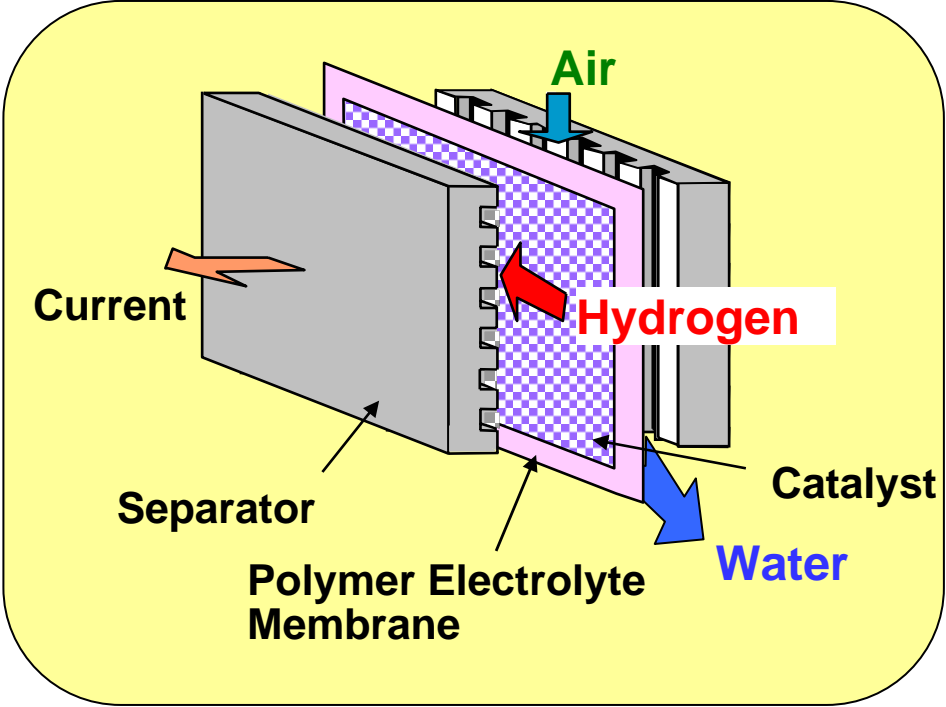

Single Cell



Stacking



Stack

FC Stack Assembly



# TOYOTA FCHV



# SUZUKI FCV



# NISSAN 2003 Model X-TRAIL FCV



The high-power motor generates a maximum power of approximately 85 kW. The cruising range has been extended to more than 350 km.

# HONDA FCX



## FCX with HONDA FC Stack

- \* No. of occupants: 4
- \* Max. speed: 93mph
- \* Motor max. output: 80kW

**HONDA FC Stack**  
Output: 86kW



# MITSUBISHI-FCV



# TOYOTA-HINO FCV

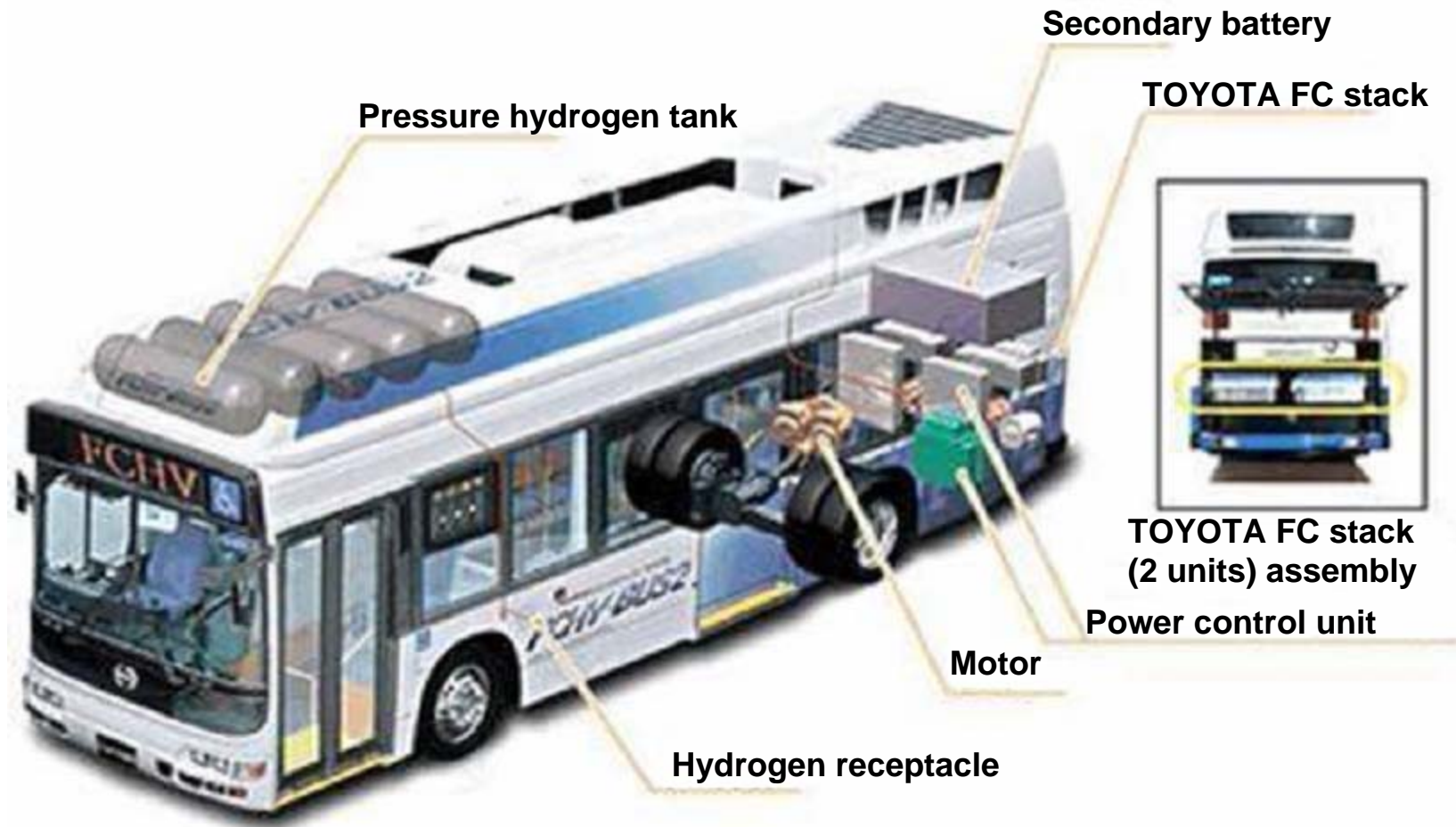

# YAMAHA FC06



Concept model mounting a DMFC system (500W)

# Japan Hydrogen & Fuel Cell Demonstration Project

1. Period: 2002 to 2004
2. Site: Tokyo, Yokohama
3. Aims: The followings concerning FCVs and hydrogen stations
  - 1) To clarify their advantages in practical use
  - 2) To collect data for codes and standards
  - 3) To familiarize the public with FCVs and stations

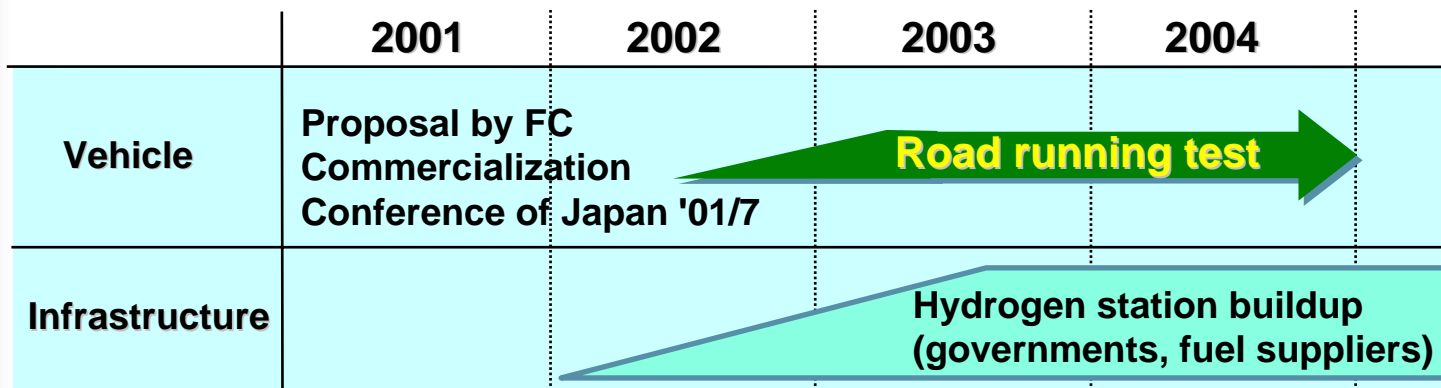

# FCV Market Challenges

## <Major Issues>

Aspect	Issues	Promoter
Technical	Temperature adaptability, high efficiency, compact size, reliability, durability (against salt water, dust, hot spring hydrogen sulfide, high-elevation condition)	Carmakers     Government, energy producers
Merchandise	Driving distance (hydrogen storage), vehicle cost	
Environmental	Recyclability, LCA	
Safety	Hydrogen, high voltage, collision	
Infrastructure	Hydrogen production/transport, service stations, hydrogen cost	

# Forecast of Automobiles in Use around the World

1. Era of co-existence of various drive systems
2. Making internal combustion engine vehicles cleaner and more efficient

